

MODUFLEX LOADING CHUTE K300

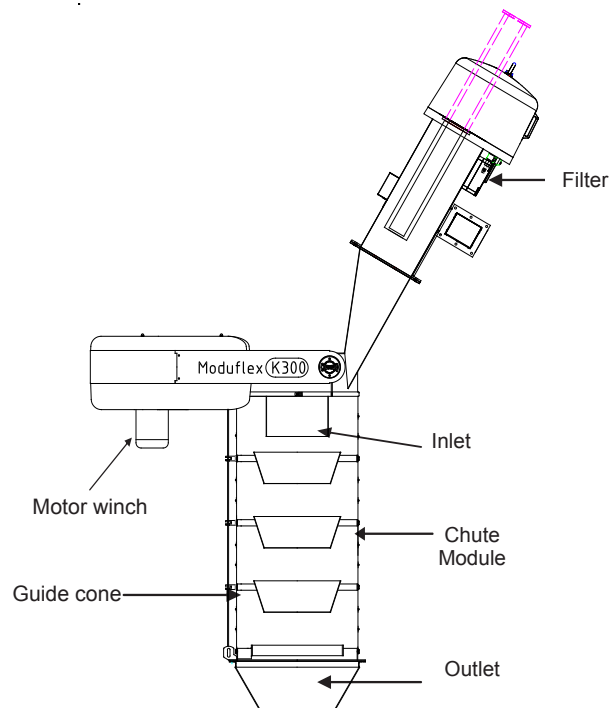

Technical Information - K300	
Inlet	Cylindrical inlet tube in 2mm steel. Fitting Ø300 PN10 flange (2576B). Mounted with 12 off M20 bolts. Sidemounted filter module with built-in cartridge filter, pressure tank, magnetic valves etc. 9 off filter cartridges, totals 9 m ² , alternatively 14m ² or 18m ² . Fan with 0,75kW motor.
Chute Modules	Type Y - Standard: Yellow. PVC/Polyester. Ø600mm/H=300mm. Temperature -35°C - +70°C Type M - Food Grade: Light Grey. PVC/Polyester. Ø600mm/H=300mm. Temperature -30°C - +70°C Type W - Special: Misc. PVC/Polyester. Ø600mm/H=300mm. Temperature -35°C - +70°C Type B - Heavy Duty: Black. Synthetic rubber. Ø600mm/H=300mm. Temperature -40°C - +130°C Type G - ExtremeTemperature: Grey. Teflon/Fiber glass. Ø600mm/H=300mm. Temperature -35°C - +260°C Type R - High Temperature: Red. Polyester and fiber/silicone rubber. Ø600/H=300. Temp. -40°C - +150°C (peak +220°C) Type Z - Low temperature: Green. PVC/PU. Ø600mm/H=300mm. Temperature -60° C - +70° C. Connection ring in stainless steel Aisi 304, c/w 3 off wire guides in nylon.
Guide Cones	Type O - Support ring. Steel, H=30mm Type U - Ultramid. Polyamide 6.6. H=150mm, pt=6mm. Type J - Steel Standard. Steel, H=150mm, pt=2mm.
Outlet	Type T – Tank Outlet with steel cone for loading in tanker truck. Type F – Flat Outlet with dust skirt for loading in open truck. Type M – Multi Outlet with steel cone and dust skirt for loading in tanker truck and open truck.
Motor Winch	Motor 0.55-2.2 kW, 1400 rpm. Gear box ratio 100:1. Tight and slack wire indication External 3-point wire hoist system with high precision ball bearings and 3 off winch discs vertically fitted. Hoist wires Ø5mm available in steel, stainless steel Aisi316 or Long Life steel quality. Self-lubricating wire rollers in Ertalite TX, alternatively steel/stainless steel with bronze bearing
General info	Max. loading capacity approx. 250 m ³ /hour. Compressed air supply, clean and dry for filter: Connection 5-6 bar. Filter cleaning air consumption 100-150 NL/min. Pressure air connection ½". Metal parts available in painted steel st. 37 or stainless steel Aisi 304. Other steel qualities on demand. Surface treatment St. 37: Iron phosphating, 80 micron coating RAL 9010 pure white. Surface treatment Aisi 304: Acid-washed without any further treatment Motor winch covers in ABS - RAL 6005 dark green. Cover on filter RAL 6005 Available with full approval and certificates for location in ATEX zone 21 and 22 (zone 20 inside the chute)

Accessories for Loading Chute K300 please see separate Data Sheets.